

P.O. BOX 11845 TUCSON, AZ 85734 • 1391 E. WIEDING ROAD TUCSON, AZ 85706
 (520) 284-3292 • FAX (520) 741-2837
www.iotaengineering.com

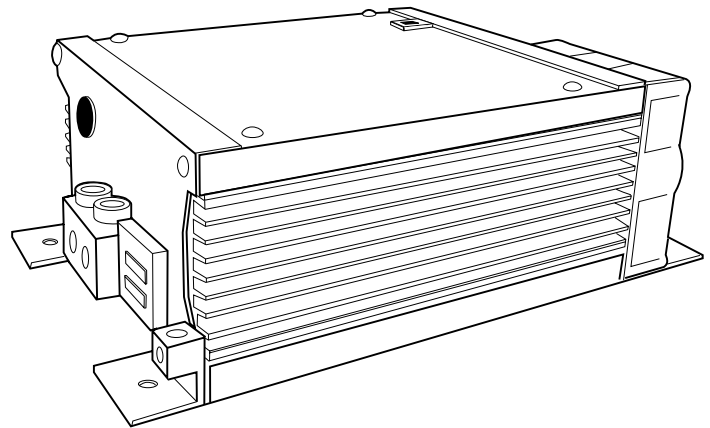

The DLS series power converter/battery charger from IOTA Engineering converts 120 volts nominal A.C. to 13.6 volts D.C. As a power supply, its tightly controlled regulation allows the user to operate any 12 volt nominal D.C. load up to the converter's rated output current. As a battery charger, the converter will maintain the battery, delivering its full-rated current when the battery capacity falls sufficiently low. The voltage is set to deliver its maximum current for the necessary period of time that minimizes undue stress to the battery caused by heating of its cells. This helps to ensure the longest possible life of the battery. Over time, as the battery nears its full capacity, the converter will float-charge the battery to prevent self-discharge of its cells.

PROTECTION FEATURES

The DLS series power converter/battery charger is designed with high quality components to help ensure years of continuous use. The DLS series is protected by multiple protection features for a long, trouble-free life.

1) *Reverse Battery Polarity Protection.* 2) *Brown-Out Input Protection.* 3) *Over-Current Protection* - cycle by cycle peak limiting as well as rated current limiting to maximize the life of the converter. 4) *Over-Temperature Protection.* In addition, it is designed with a unique "proportional" fan control circuit. Fan speed is directly proportional to the converter's internal ambient temperature. This enables the fan to turn on and off very slowly, minimizing unwanted fan-starting noise.

WARRANTY

The DLS series power converter/battery charger is warranted from defects in materials or workmanship for two years from date of retail purchase, and limits the remedies to repair or replacement. This warranty is valid only in the continental United States and Canada.

MODEL	DLS 15	DLS 30	DLS 45	DLS 55	DLS 75
INPUT VOLTS (Vac)	108-132	108-132	108-132	108-132	108-132
FREQUENCY (Hz)	40-70	40-70	40-70	40-70	40-70
MAX AMP DRAW (AC)	4	8	12	15	18
MAX WATT DRAW (VA)	280.8 (432)	561.6 (864)	842.4 (1296)	1053 (1620)	1263.6 (1944)
OUTPUT AMPS (DC)	15	30	45	55	75
OUTPUT VOLTS (DC)	13.4-14.0 @ FULL LOAD				
DIMENSIONS*					
WIDTH	6.45"	6.45"	6.45"	6.45"	6.45"
LENGTH	7"	7"	7"	7"	10"
HEIGHT	3.42"	3.42"	3.42"	3.42"	3.42"

*DETAILED MOUNTING SPECIFICATIONS ARE AVAILABLE ONLINE AT WWW.IOTAENGINEERING.COM

Distributed By:

INSTALLATION GUIDELINES

There are no components within the DLS unit that, in their normal operation, produce arcs or sparks. However, all electronic devices have some potential for generating sparks in the event of failure. Therefore, never install this device in the same compartment with flammable items such as gasoline or batteries.

MOUNTING LOCATION

The DLS battery charger/power supply can be mounted in any position within an enclosed or interior compartment. Provide sufficient air space to allow unrestricted airflow in and around the unit.

DLS INSTALLATION

Disconnect the positive side of the battery before installation. Connect the positive (red) and negative (black) terminal lugs to battery or load. Always use the proper size wire based on the amperage of the converter and the battery. When connecting to a battery, a breaker should be installed within 18" of the battery, connecting the battery positive to the line side of the breaker, and the DLS to the load side. Connect "Chassis Bonding Lug" on the DLS to vehicle chassis or other grounding source.

120 VOLT A.C. INPUT

Plug the DLS A.C. input cord into a 120 volt 3 wire grounded source. See chart for maximum current draw and required input voltages.

REVERSE POLARITY FUSES

The DLS Battery Charger/Power Supply is protected against reverse polarity on the DC output. If a battery or the DLS is hooked up incorrectly, the fuses will blow and can be easily replaced. Always use the same size and style fuse that came with the converter. To change the fuses, use a screwdriver to loosen the screws and remove the fuses. Always replace the fuses with the same type and rating. After inserting the new fuses, tighten the screws firmly. DO NOT OVERTIGHTEN.

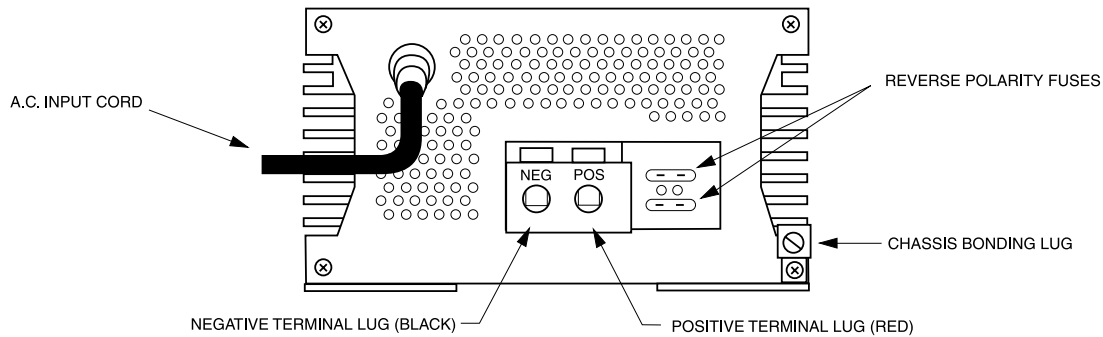

CHARGE CONTROLLER OPTIONS

Charge Controller Options are designed for DLS units that DO NOT have the IQ SMART CONTROL FEATURE internally integrated. It is not necessary to utilize the Dual Voltage Jack or External IQ Controller for IQ-integrated DLS units.

TWO-STEP VOLTAGE JACK

The two-step voltage jack (located on the top of the DLS on the fan-end of the unit) allows switching from a long-term float voltage of 13.6vdc up to 14.2vdc. When the included dual voltage plug is inserted in the jack, the voltage rises to 14.2vdc for occasional fast charging. When the plug is removed, the voltage drops to 13.6vdc to reduce battery water loss. **WARNING: To avoid battery damage, remove the Dual Voltage Plug when quick-charging is complete.**

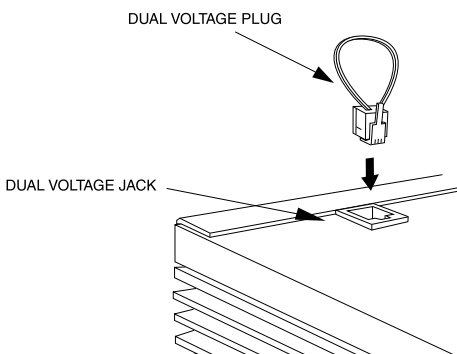

IQ SMART CHARGER

DLS power converters/chargers are designed to accommodate the IQ smart charge controller. The microprocessor-controlled charger turns the DLS charger into an "automatic" 3-stage "smart charger," giving the user the benefit of Bulk, Absorption, and Float stage charging. This increases the charging capacity of the DLS charger, decreases charge times and insures proper and safe battery charging without over-charging. The IQ controller inserts into the dual voltage jack on the DLS.

